

Concurrent and parallel programming

Romolo Marotta

Trend in processor technology

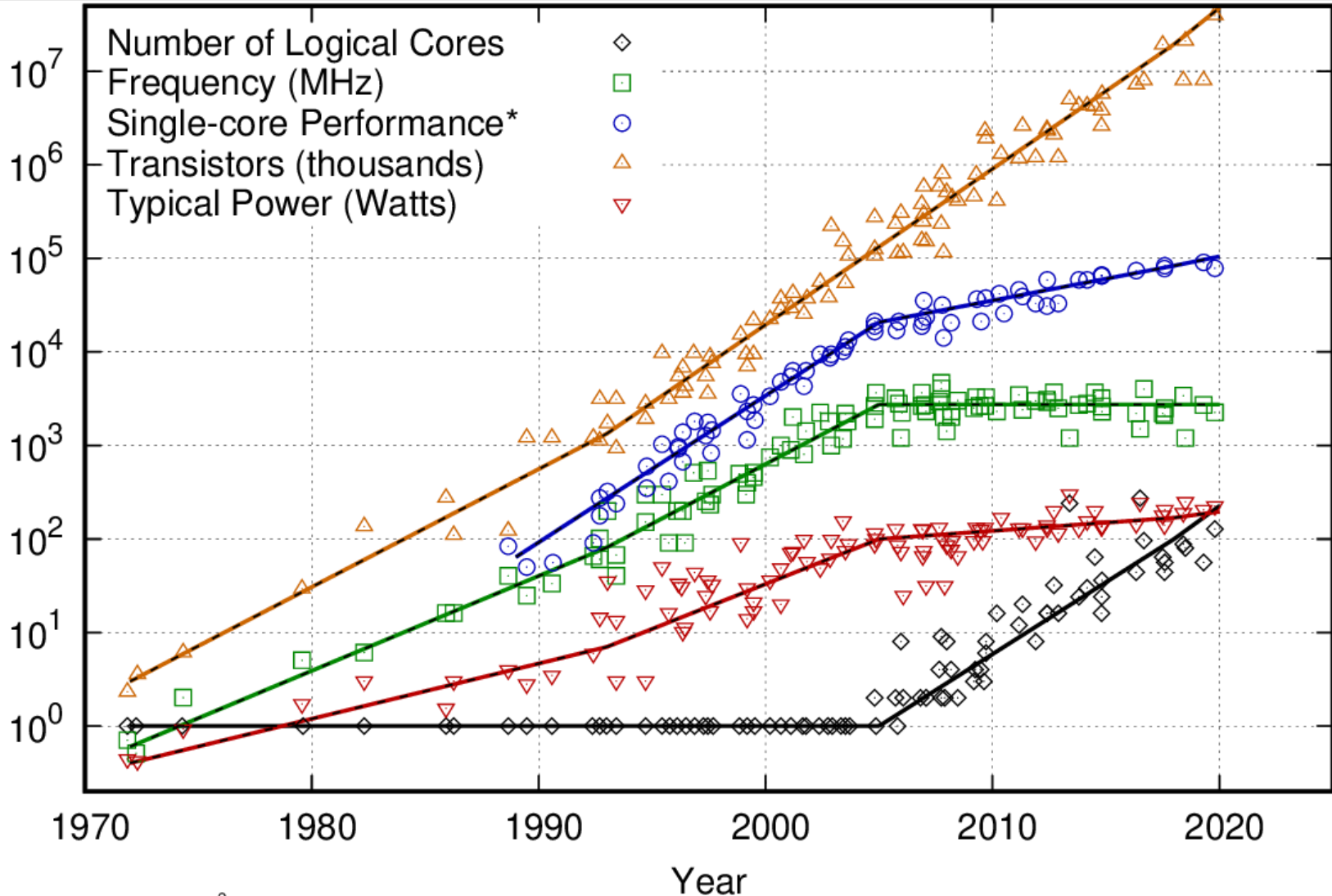

*SpecINT x 10^3

Original data up to the year 2010 collected and plotted by M. Horowitz, F. Labonte, O. Shacham, K. Olukotun, L. Hammond, and C. Batten
New plot and data collected for 2010-2018 by K. Rupp

On concurrent programming

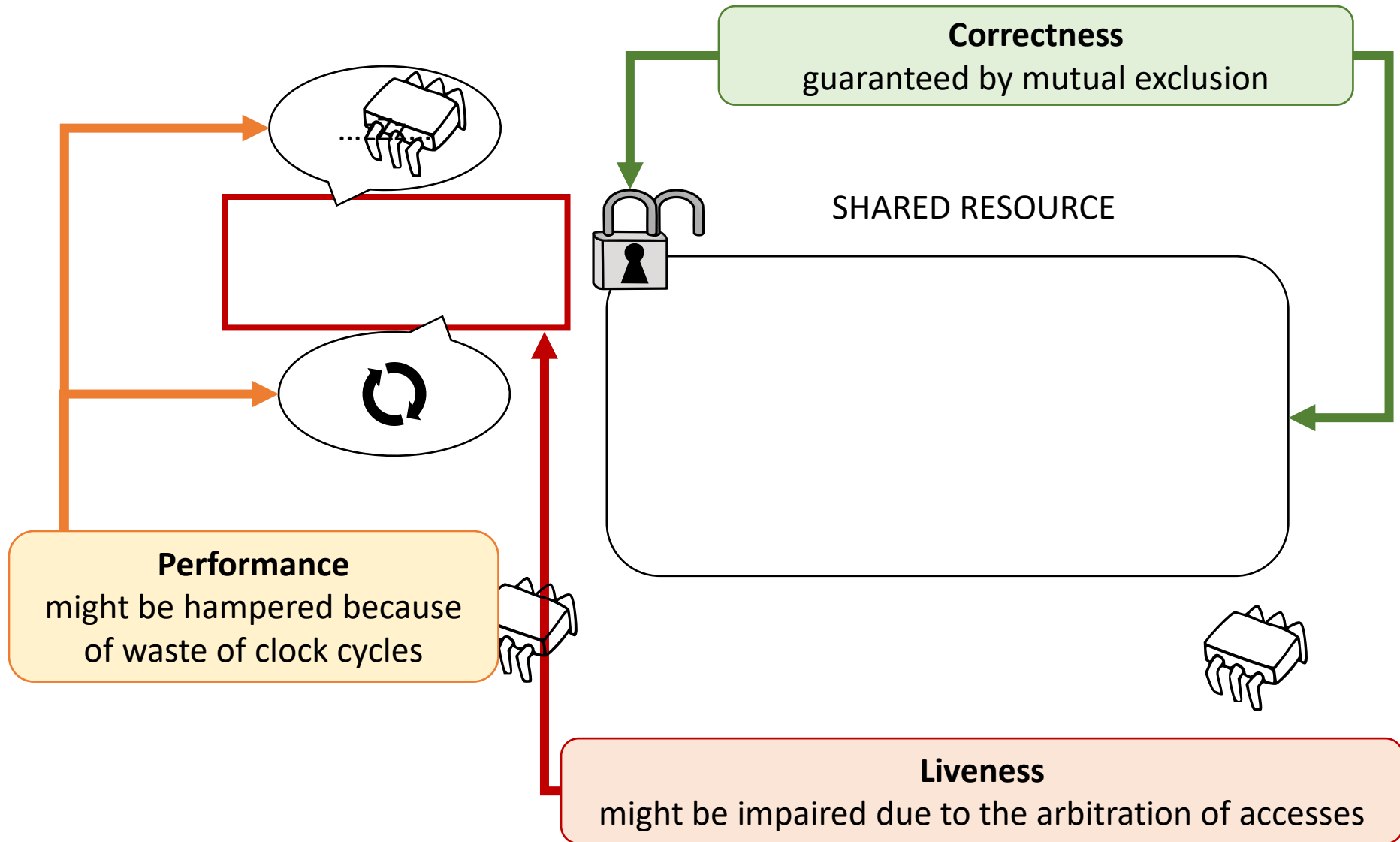

Parallel programming

- Ad-hoc concurrent programming languages
- Development tools
 - Compilers
 - MPI, OpenMP, libraries
 - Tools to debug parallel code (gdb, valgrind)
- Writing parallel code is an art
 - There are approaches, not prepackaged solutions
 - Every machine has its own singularities
 - Every problem to face has different requisites
 - The most efficient parallel algorithm might **not** be the most intuitive one

What do we want from parallel programs?

- **Safety:** *nothing wrong happens* (Correctness)
 - parallel versions of our programs should be correct as their sequential implementations
- **Liveliness:** *something good happens eventually* (Progress)
 - if a sequential program terminates with a given input, we want that its parallel alternative also completes with the same input
- **Performance**
 - we want to exploit our parallel hardware

Correctness conditions

Progress conditions

Performance

Classical approach to concurrent programming

Based on blocking primitives

- Semaphores
- Locks acquiring
- Simple??

PRODUCER

```
1. Semaphore p, c = 0;  
2. Buffer b;  
3.  
4. while(1) {  
5. wait(c);  
6. <Write on b>  
7. signal(p);  
8. }
```



CONSUMER

```
1. Semaphore p, c = 0;  
2. Buffer b;  
3.  
4. while(1) {  
5. wait(p);  
6. <Read from b>  
7. signal(c);  
8. }
```



Correctness

- What does it mean for a program to be correct?
 - What's exactly a concurrent FIFO queue?
 - FIFO implies a strict temporal ordering
 - Concurrency implies an ambiguous temporal ordering
- Intuitively, if we rely on locks, changes happen in a non-interleaved fashion, resembling a sequential execution
- We can say a concurrent execution is correct only because we can associate it with a sequential one, which we know the functioning of
- An execution is correct if it is equivalent to a correct sequential execution

Correctness

- An **execution** is correct if it is equivalent to a correct **sequential execution**

A simplified model of a concurrent system

- A concurrent system is a collection of sequential threads/processes that communicate through shared data structures called objects.
- An object has a unique name and a set of primitive operations.

A simplified model of a concurrent execution

- A *history* is a sequence of invocations and replies generated on an object by a set of threads

- Invocation:

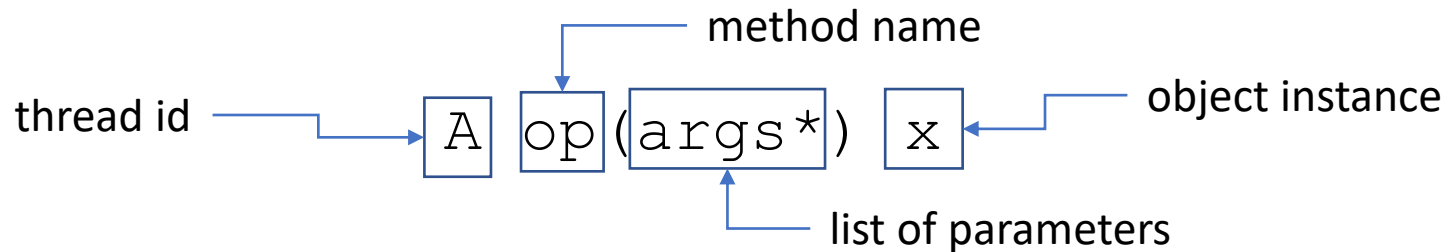

- Reply:

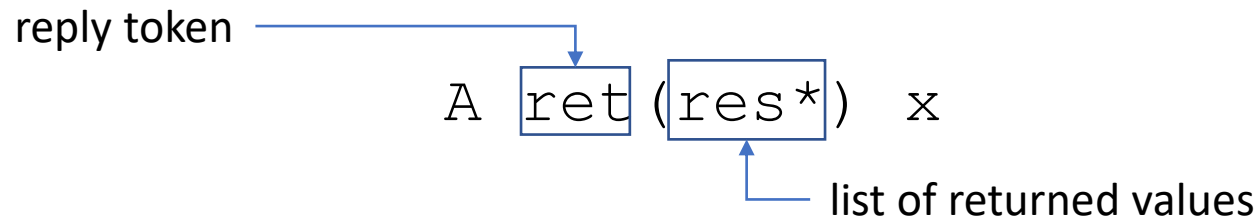

A simplified model of a concurrent execution

- A *sequential history* is a history where all the invocations have an immediate response
- A *concurrent history* is a history that is not sequential

Sequential

```
H': A op() x
     A ret() x
     B op() x
     B ret() x
     A op() y
     A ret() y
```

Concurrent

```
H:  A op() x
     B op() x
     A ret() x
     A op() y
     B ret() x
     A ret() y
```

Correctness

- An **execution** is correct if it is equivalent to a correct **sequential execution**
- ⇒ A **history** is correct if it is **equivalent** to a correct **sequential history**

A simplified model of a concurrent execution

- A *process subhistory* $H|P$ of a history H is the subsequence of all events in H whose process names are P

```
H:  A op()  x
     B op()  x
     A ret() x
     A op()  y
     B ret() x
     A ret() y
```

```
H|A: A op()  x
      A ret() x
      A op()  y
      A ret() y
```

- Process subhistories are always sequential

Equivalence between histories

- Two histories H and H' are equivalent if for every process P , $H|P=H'|P$

H: A op() x
B op() x
A ret() x
A op() y
B ret() x
A ret() y

H': B op() x
B ret() x
A op() x
A ret() x
A op() y
A ret() y

H|A:
H'|A: A op() x
A ret() x
A op() y
A ret() y

H|B:
H'|B: B op() x
B ret() x

Correctness conditions

- A **concurrent execution** is correct if it is equivalent to a correct **sequential execution**
- ⇒ A **history** is correct if it is **equivalent** to a ~~correct~~ **sequential history** which satisfies a given correctness condition
- A correctness condition specifies the set of histories to be considered as reference
- ⇒ In order to implement correctly a concurrent object wrt a correctness condition, we must guarantee that every possible history on our implementation satisfies the correctness condition

Sequential Consistency [Lamport 1970]

- A history H is sequentially consistent if
 1. it is equivalent to a sequential history S
 2. S is legal according to the sequential definition of the object
- ⇒ An object implementation is sequentially consistent if every history associated with its usage is sequentially consistent

Sequential Consistency [Lamport 1970]

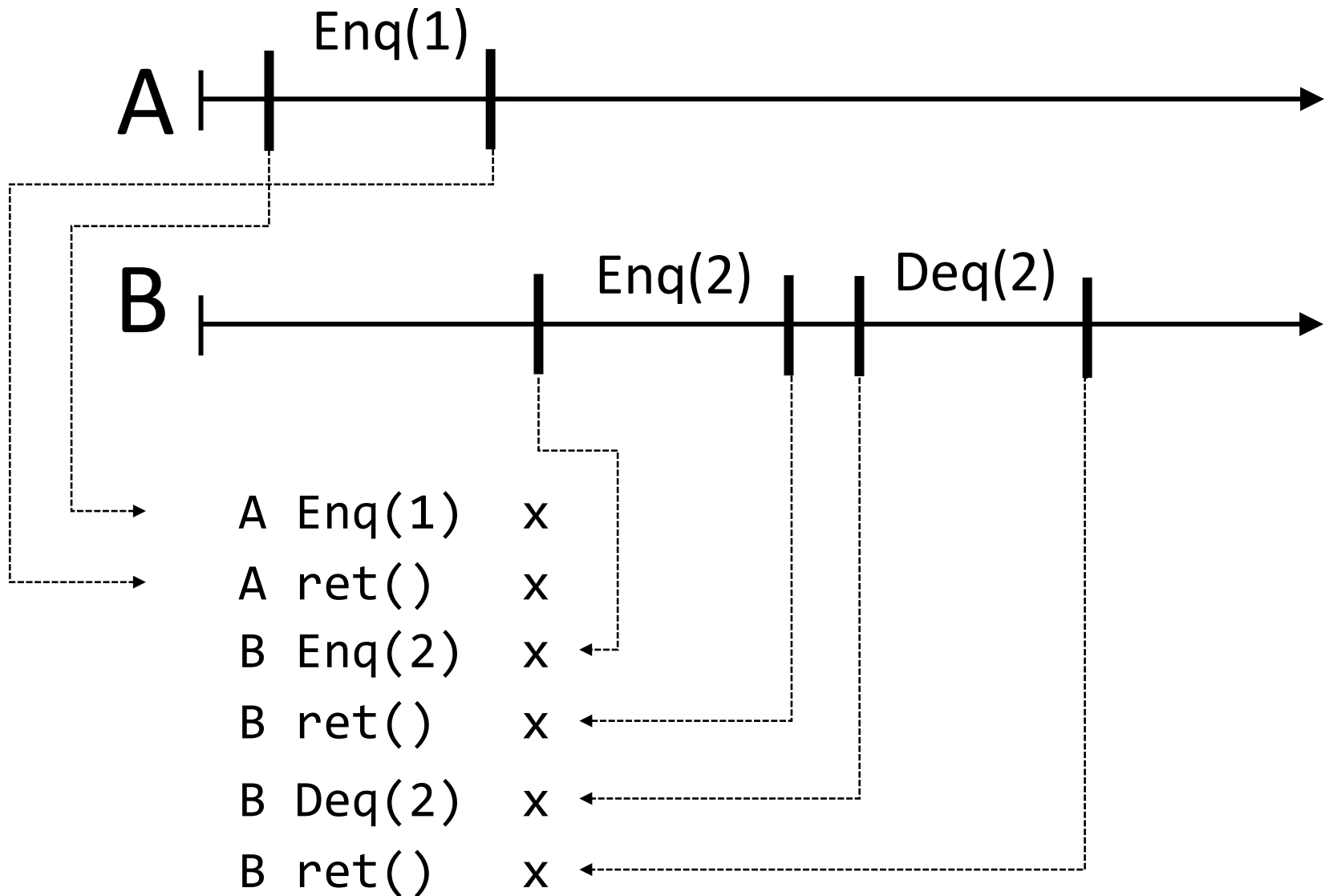

Sequential Consistency [Lamport 1970]

H|A:

- H' is legal and sequential
- H is equivalent to H'
- H is correct w.r.t sequential consistency

H:

A	Enq(1)	x
A	ret()	x
B	Enq(2)	x
B	ret()	x
B	Deq(2)	x
B	ret()	x

H' :

B	Enq(2)	x
B	ret()	x
A	Enq(1)	x
A	ret()	x
B	Deq(2)	x
B	ret()	x

Linearizability [Herlihy 1990]

- A concurrent execution is linearizable if:
 - Each procedure appears to be executed in an indivisible point (*linearization point*) between its invocation and completion
 - The order among those points is correct according to the sequential definition of objects

Linearizability [Herlihy 1990]

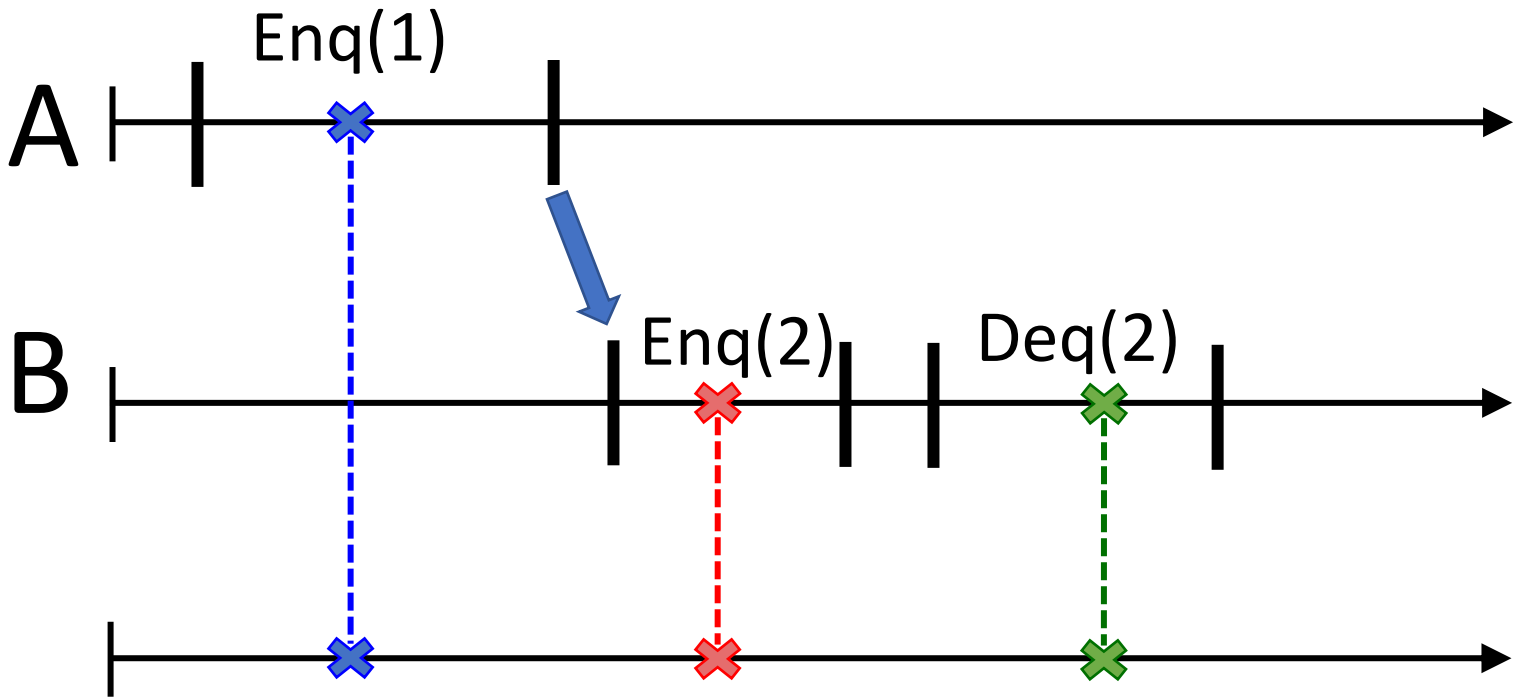

Linearizability [Herlihy 1990]

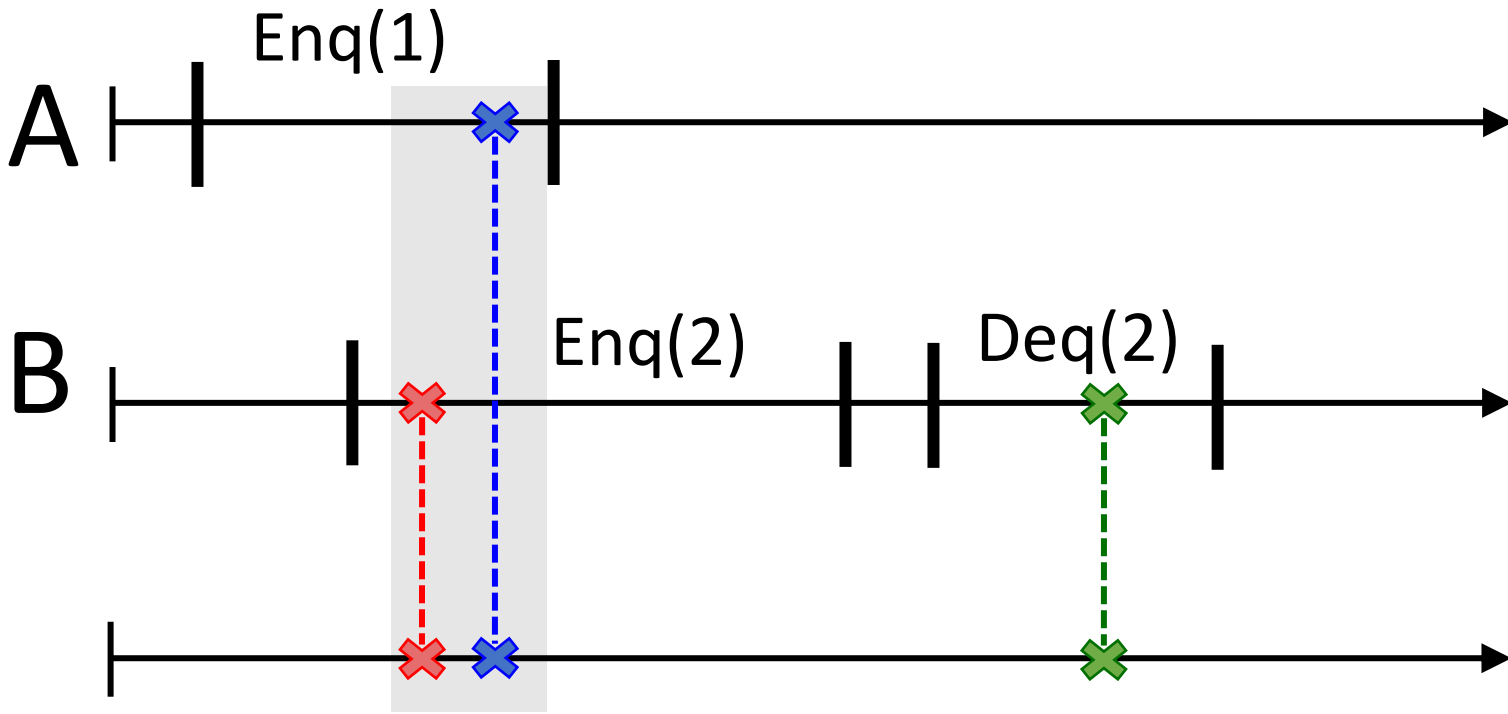

Linearizability [Herlihy 1990]

- A history H is linearizable if:
 1. it is equivalent to sequential history S
 2. S is correct according to the sequential definition of objects
 3. If a response precedes an invocation in the original history, then it must precede it in the sequential one as well
- ⇒ An object implementation is linearizable if every history associated with its usage can be linearized

Linearizability [Herlihy 1990]

- Linearizability requires:
 - Sequential Consistency
 - Real-time order
- Linearizability \Rightarrow Sequential Consistency
- The composition of linearizable histories is still linearizable
- Linearizability is a *local* property (closed under composition)

Quick look on transaction correctness conditions

- We can see a transaction as a set of procedures on different object that has to appear as atomic
- Serializability requires that transactions appear to execute sequentially, i.e., without interleaving.
 - A sort of sequential consistency for multi-object atomic procedures
- Strict-Serializability requires the transactions' order in the sequential history is compatible with their precedence order
 - A sort of linearizability for multi-object atomic procedures

A bird's eye view on correctness conditions

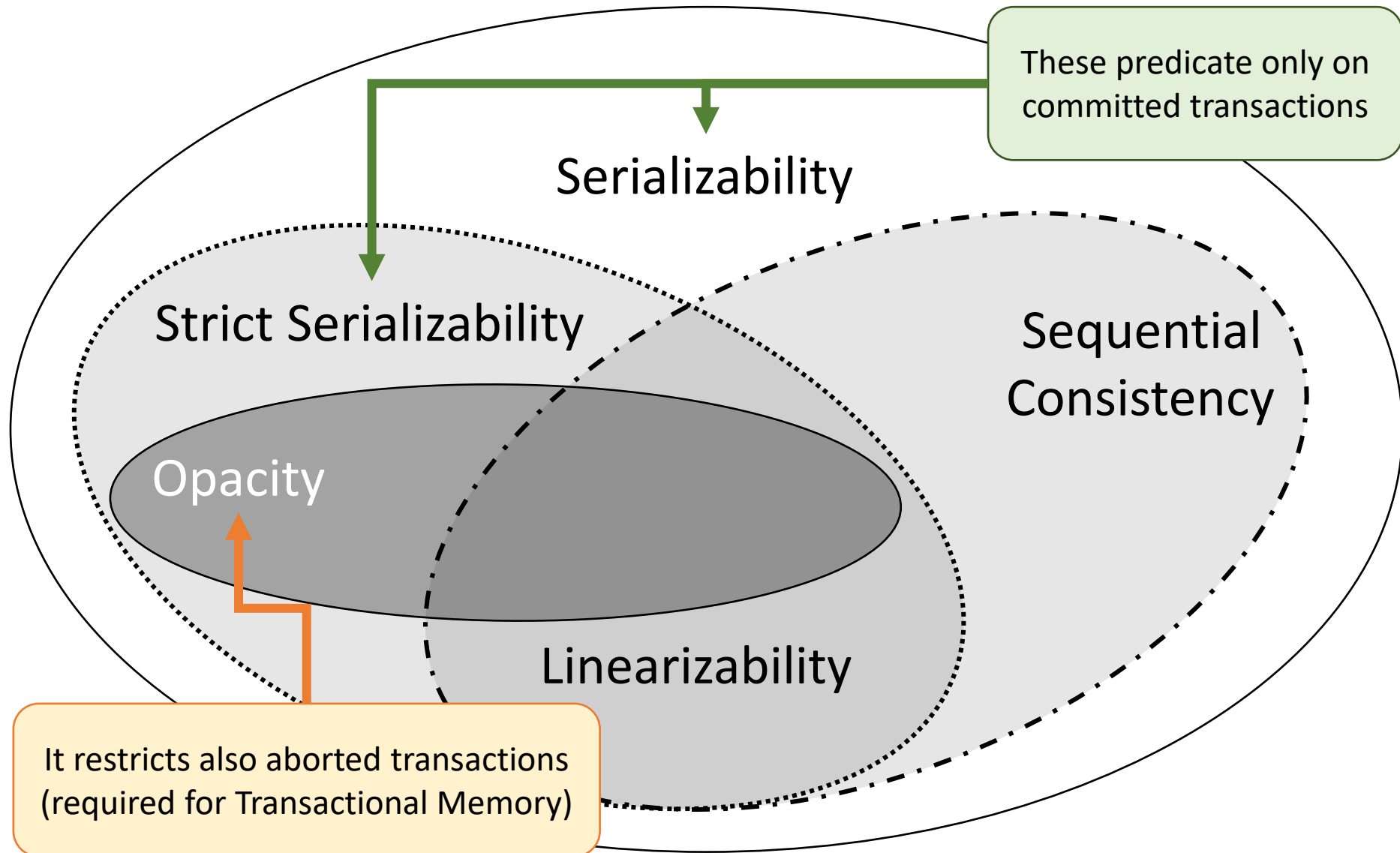

Correctness conditions (incomplete) taxonomy

	Sequential Consistency	Linearizability	Serializability	Strict Serializability
Equivalent to a sequential order	✓	✓	✓	✓
Respects program order in each thread	✓	✓	✓	✓
Consistent with real-time ordering	✗	✓	✗	✓
Access multiple objects atomically	✗	✗	✓	✓
Locality	✗	✓	✗	✗

Correctness conditions
Progress conditions
Performance

Progress conditions

- **Deadlock-freedom:**
 - *Some thread acquires a lock eventually*
- **Starvation-freedom:**
 - *Every thread acquires a lock eventually*

Blocking synchronization

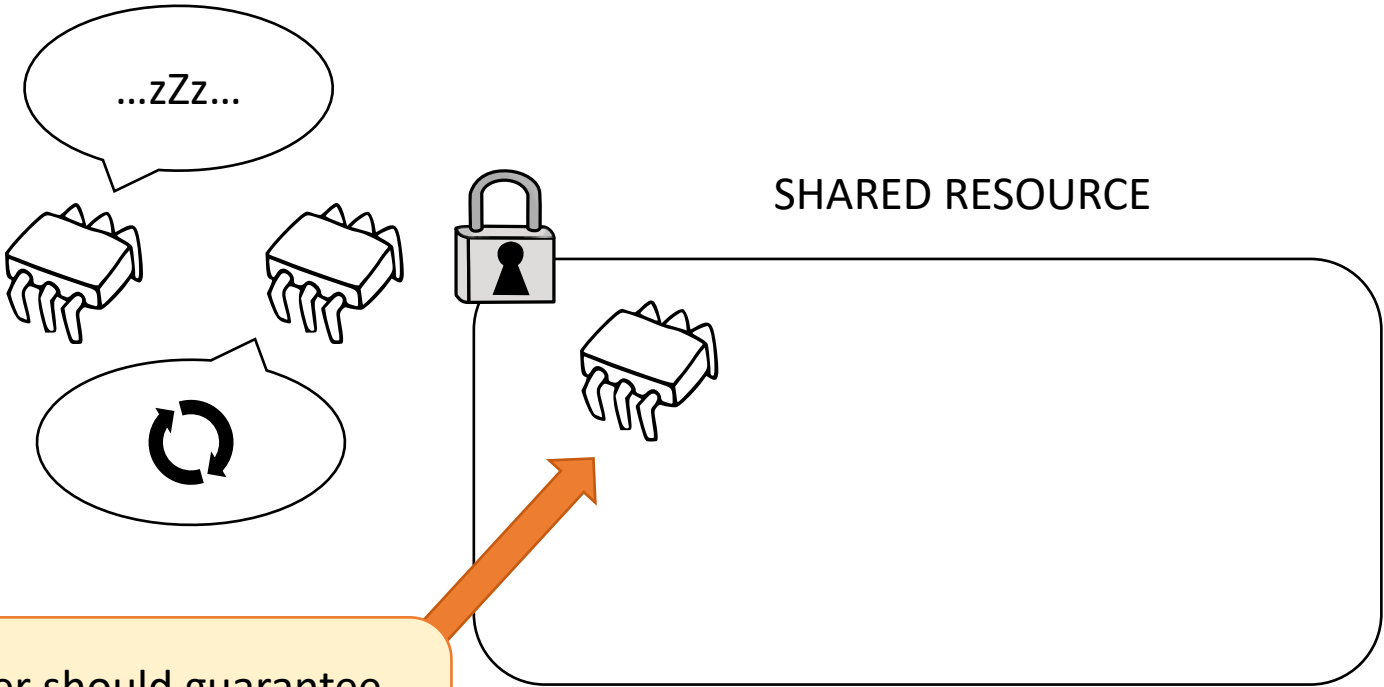

The scheduler should guarantee that the thread holding the lock completes its critical section

Scheduler's role

Progress conditions on multiprocessors

- Are not only about guarantees provided by a method implementation
- Are also about the scheduling support needed to provide progress

Requirement for lock-based applications

- Fair histories

Every thread takes an infinite number of concrete steps

Progress conditions

- **Deadlock-freedom:**
 - ~~Some thread acquires a lock eventually~~
 - *Some method call completes in every fair execution*
- **Starvation-freedom:**
 - ~~Every thread acquires a lock eventually~~
 - *Every method call completes in every fair execution*
- **Lock-freedom:**
 - *Some method call completes in every execution*
- **Wait-freedom:**
 - *Every method call completes in every execution*
- **Obstruction-freedom:**
 - *Every method call, which executes in isolation, completes*

Progress taxonomy

	Non-blocking		Blocking
For everyone	Wait freedom	Obstruction freedom	Starvation freedom
For someone	Lock freedom		Deadlock freedom

Progress taxonomy

	Non-blocking		Blocking
For everyone	-	Thread executes in isolation	Fairness
For someone	-		Fairness

Progress taxonomy

	Independent	Dependent	
	Non-blocking		Blocking
For everyone	Wait freedom	Obstruction freedom	Starvation freedom
For someone	Lock freedom		Deadlock freedom

- The Einsteinium of progress conditions: it does not exist in nature and (maybe) has no “commercial” value
- Clash freedom is a strictly weaker property than obstruction freedom

Correctness conditions

Progress conditions

Performance

The cost of synchronization

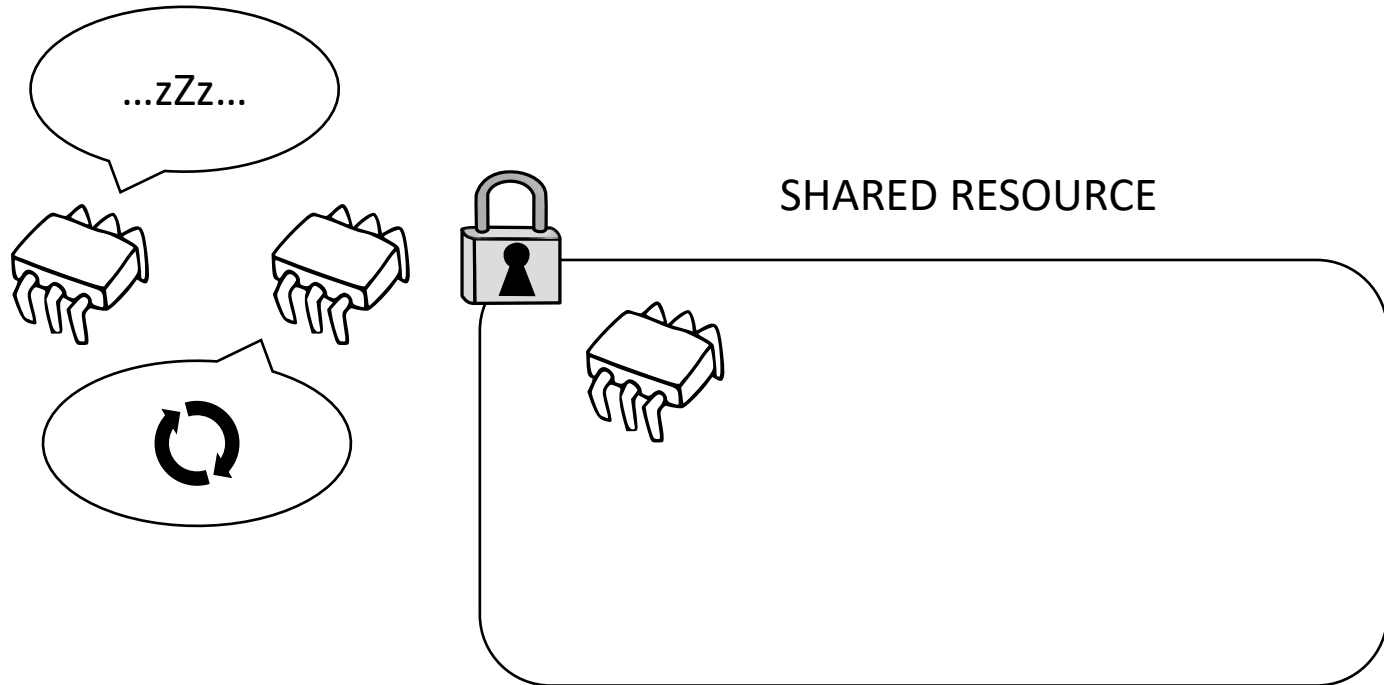

The cost of synchronization

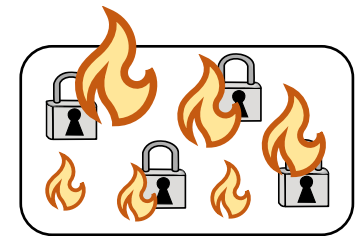
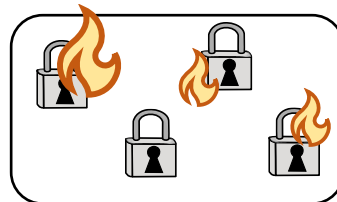
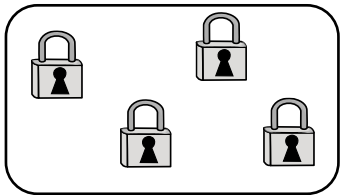
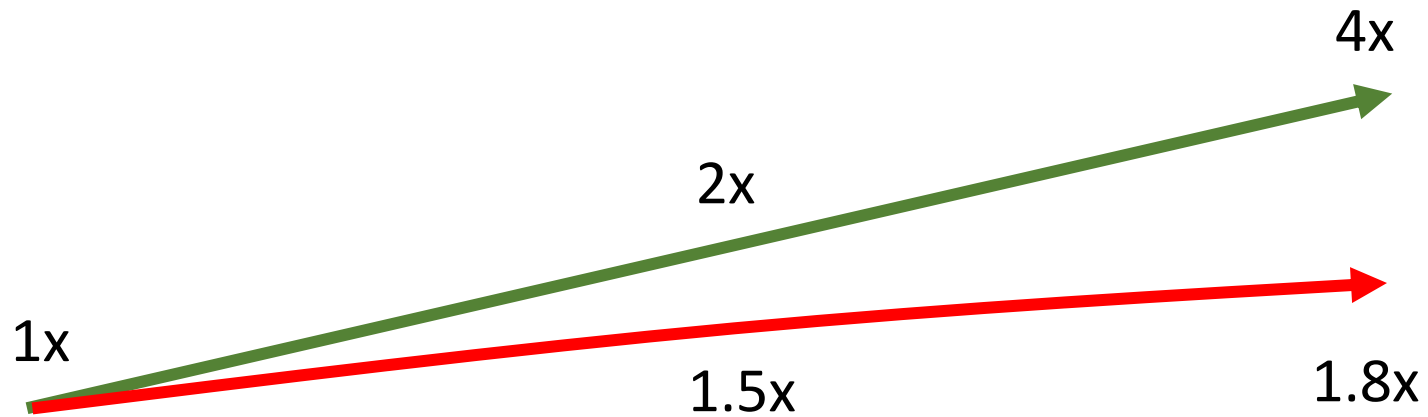

Amdahl Law – Fixed-size Model (1967)

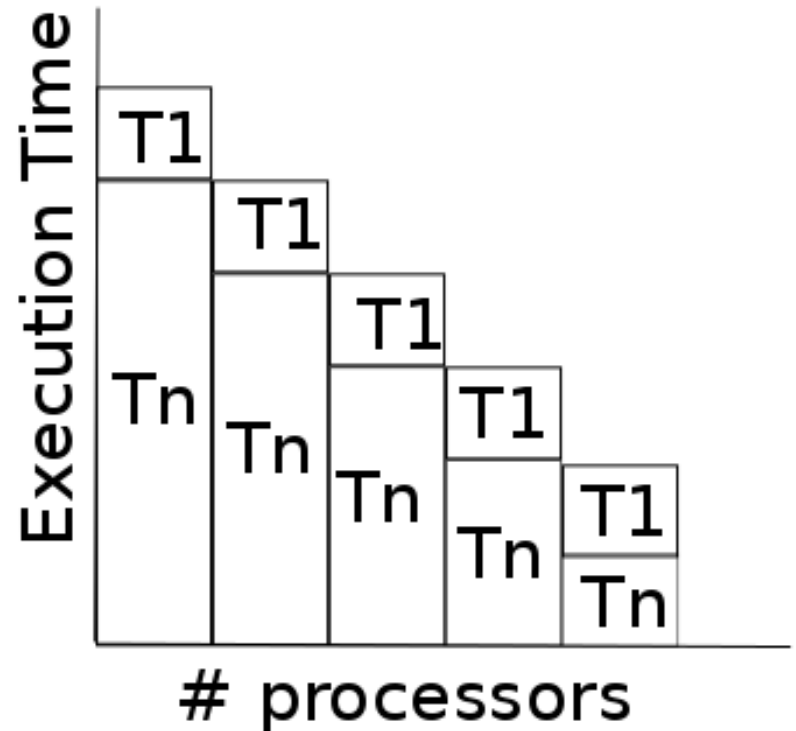
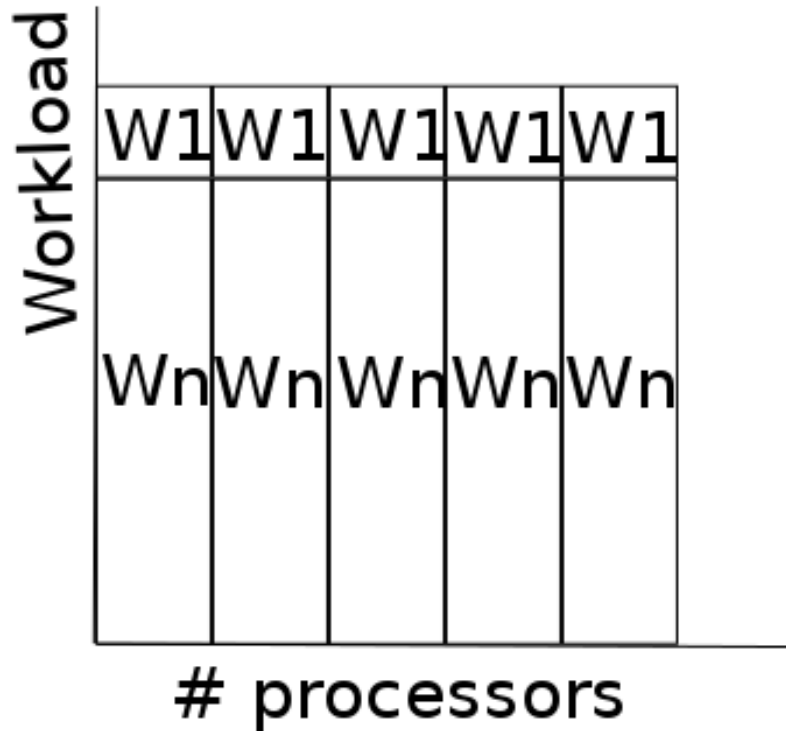

Amdahl Law – Fixed-size Model (1967)

- The workload is fixed: it studies how the behavior of the same program varies when adding more computing power

$$S_{Amdahl} = \frac{T_s}{T_p} = \frac{T_s}{\alpha T_s + (1 - \alpha) \frac{T_s}{p}} = \frac{1}{\alpha + \frac{(1 - \alpha)}{p}}$$

- where:
 - $\alpha \in [0,1]$: Serial fraction of the program
 - $p \in \mathbb{N}$: Number of processors
 - T_s : Serial execution time
 - T_p : Parallel execution time
- It can be expressed as well vs. the parallel fraction

$$P = 1 - \alpha$$

Amdahl Law – Fixed-size Model (1967)

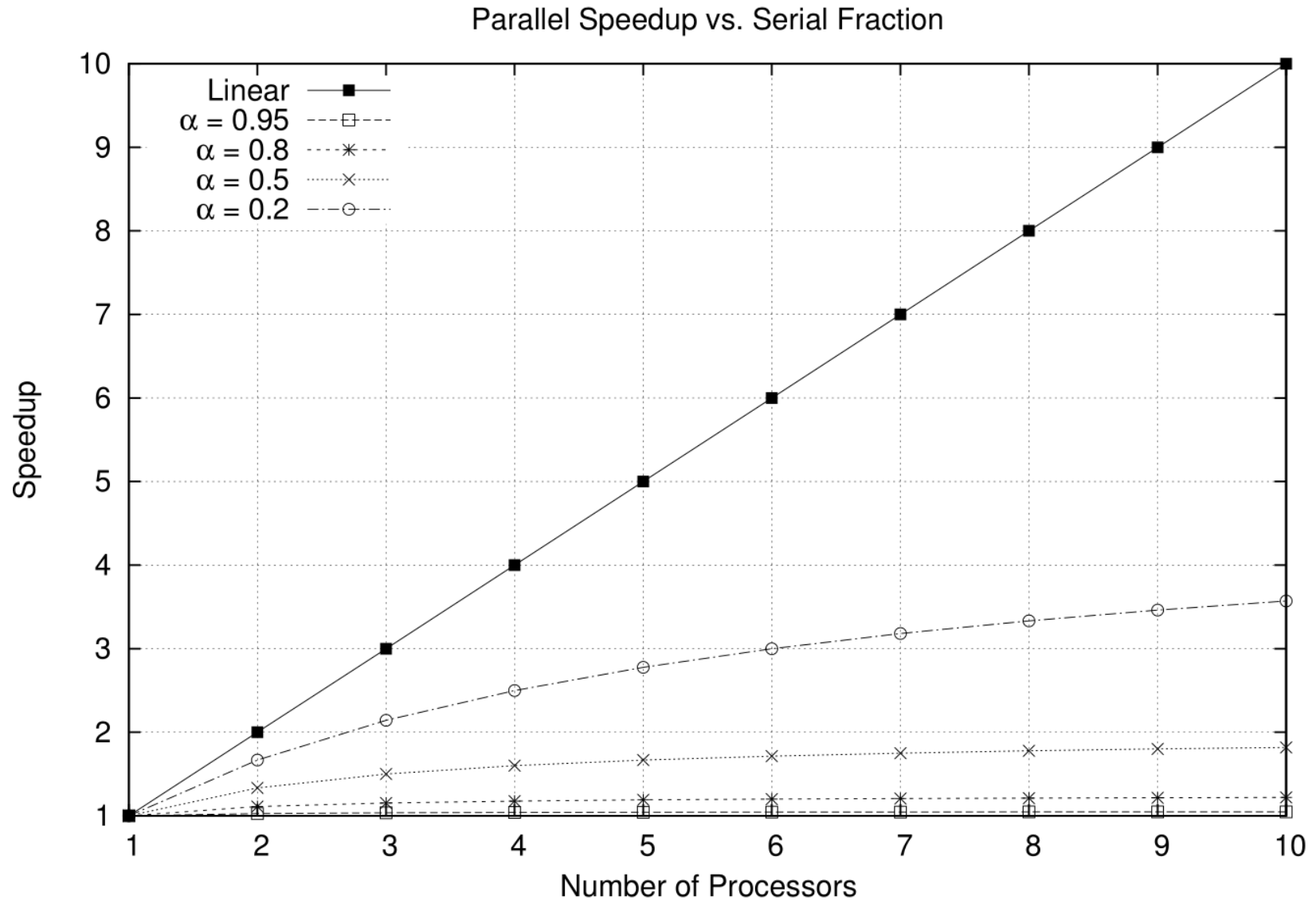

How real is this?

$$\lim_{p \rightarrow \infty} S_{Amdahl} = \lim_{p \rightarrow \infty} \frac{1}{\alpha + \frac{(1 - \alpha)}{p}} = \frac{1}{\alpha}$$

- If the sequential fraction is 20%, we have:

$$\lim_{p \rightarrow \infty} S_{Amdahl} = \frac{1}{0.2} = 5$$

- Speedup 5 using infinite processors!

Fixed-time model

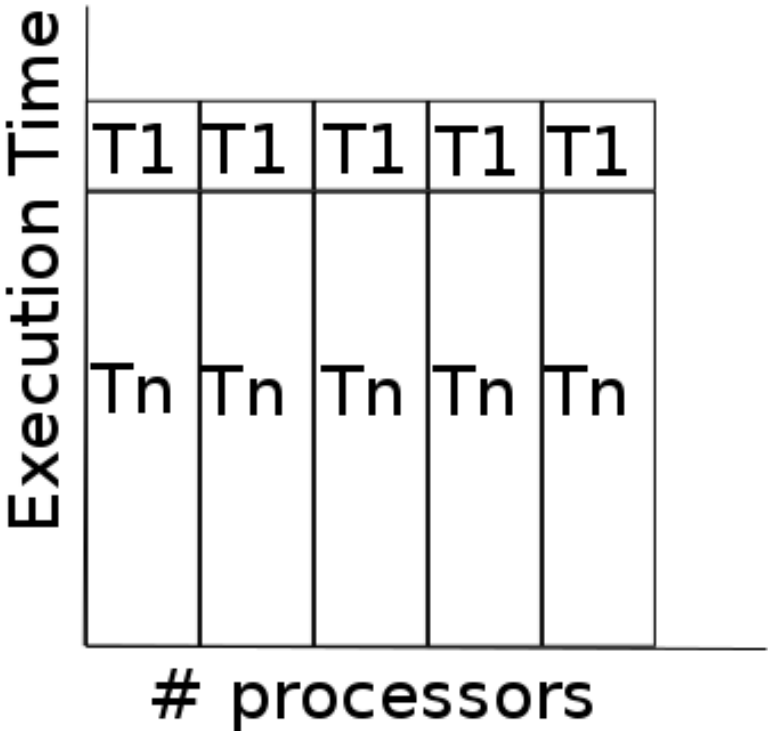
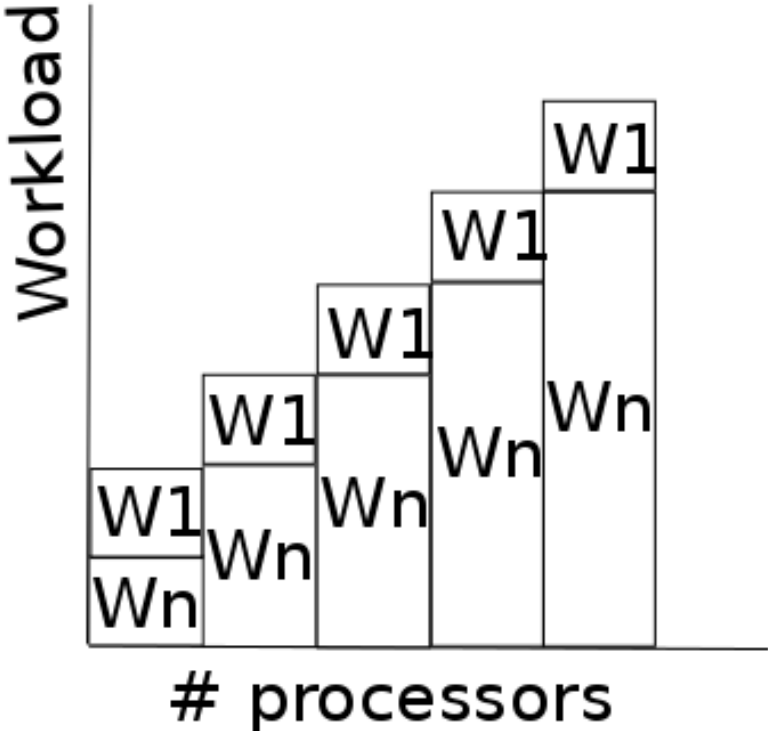

Gustafson Law—Fixed-time Model (1989)

- The execution time is fixed: it studies how the behavior of the scaled program varies when adding more computing power

$$W' = \alpha W + (1 - \alpha)pW$$

$$S_{Gustafson} = \frac{W'}{W} = \alpha + (1 - \alpha)p$$

- where:
 - $\alpha \in [0,1]$: Serial fraction of the program
 - $p \in \mathbb{N}$: Number of processors
 - W : Original workload
 - W' : Scaled workload

Speed-up according to Gustafson

Parallel Speedup vs. Serial Fraction

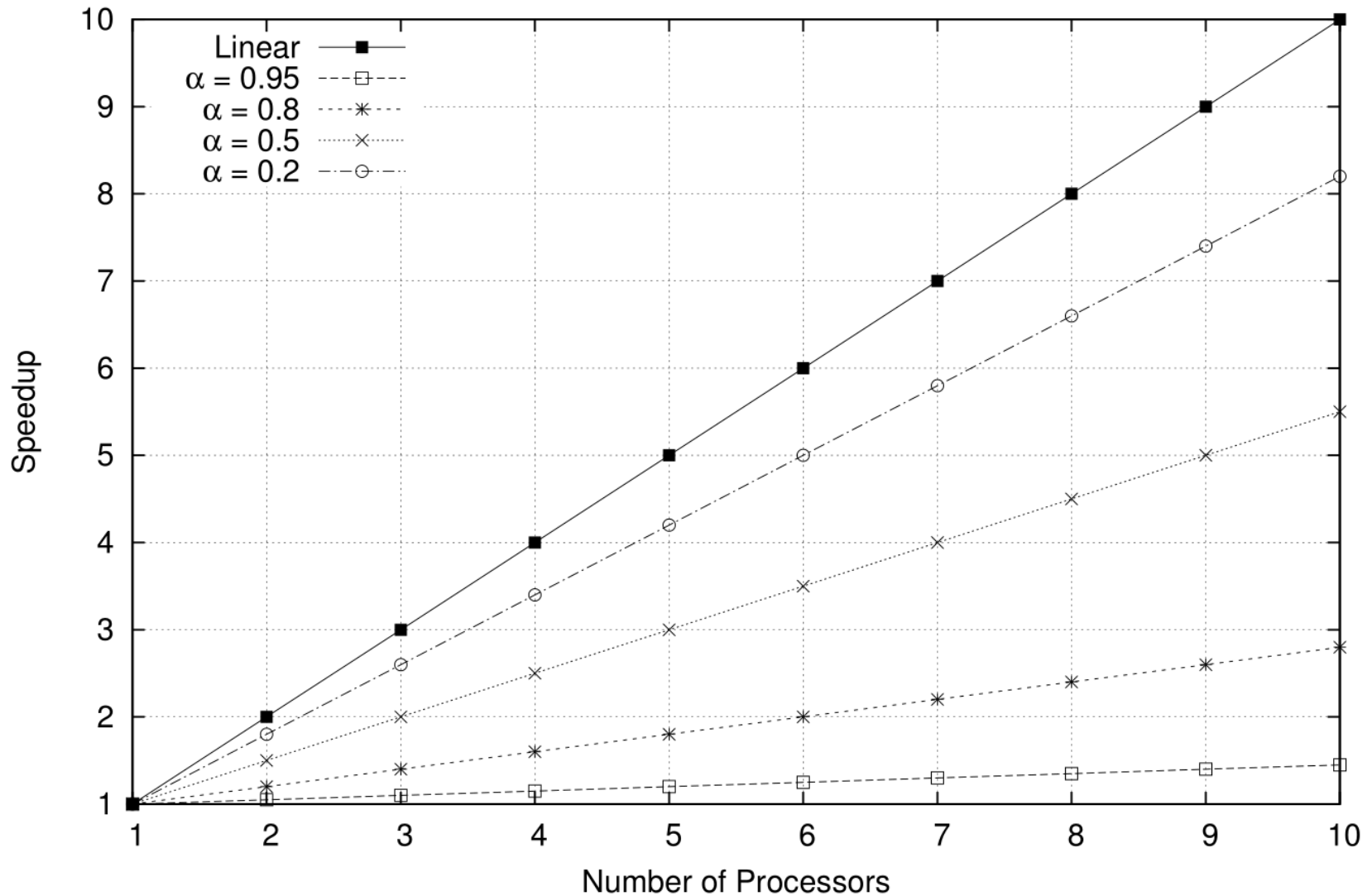

Memory-bounded model

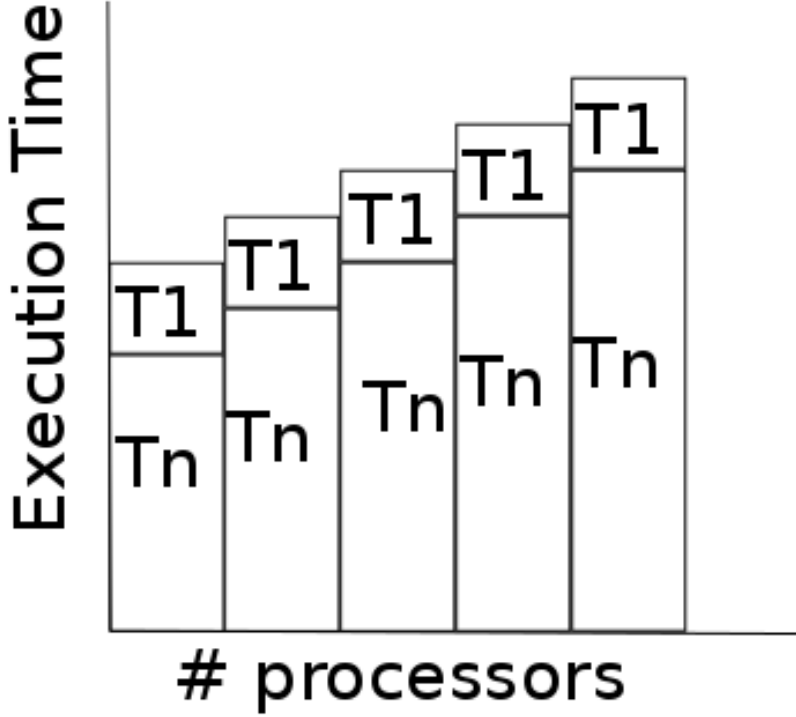
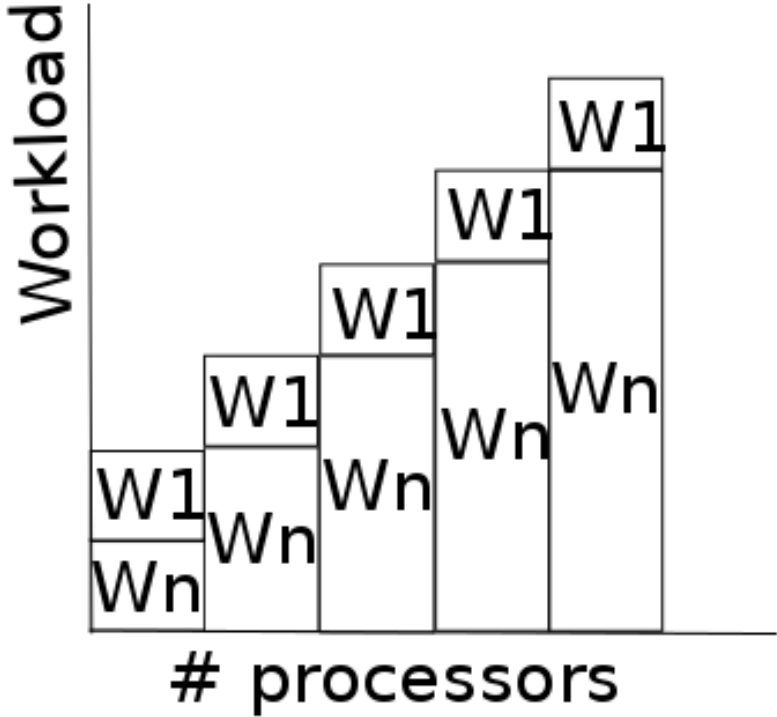

Sun Ni Law—Memory-bounded Model (1993)

- The workload is scaled, bounded by memory

$$S_{Sun-Ni} = \frac{\textit{sequential time for } W^*}{\textit{parallel time for } W^*}$$

$$S_{Sun-Ni} = \frac{\alpha W + (1 - \alpha)G(p)W}{\alpha W + (1 - \alpha)G(p)\frac{W}{p}} = \frac{\alpha + (1 - \alpha)G(p)}{\alpha + (1 - \alpha)\frac{G(p)}{p}}$$

- where:
 - $G(p)$ describes the workload increase as the memory capacity increases
 - $W^* = \alpha W + (1 - \alpha)G(p)W$

Speed-up according to Sun Ni

$$S_{Sun-Ni} = \frac{\alpha + (1 - \alpha)G(p)}{\alpha + (1 - \alpha)\frac{G(p)}{p}}$$

- If $G(p) = 1$

$$S_{Amdahl} = \frac{1}{\alpha + \frac{(1 - \alpha)}{p}}$$

- If $G(p) = p$

$$S_{Gustafson} = \alpha + (1 - \alpha)p$$

- In general, $G(p) > p$ gives a higher scale-up

Superlinear speedup

- Can we have a Speed-up $> p$? **Yes!**
 - Workload increases more than computing power ($G(p) > p$)
 - Cache effect: larger accumulated cache size. More or even all of the working set can fit into caches and the memory access time reduces dramatically
 - RAM effect: enables the dataset to move from disk into RAM drastically reducing the time required, e.g., to search it.

Scalability

- Efficiency

$$E = \frac{\textit{speedup}}{\textit{\#processors}}$$

- **Strong Scalability:** If the efficiency is kept fixed while the number of processes and maintain fixed the problem size
- **Weak Scalability:** If the efficiency is kept fixed while increasing at the same rate the problem size and the number of processes

Recommended readings

- *Linearizability: A correctness condition for concurrent objects*
M. Herlihy et al. , ACM TOPLAS, 1990
- *On the nature of progress*
M. Herlihy et al., OPODIS'11.
- *Another View on Parallel Speedup*
Sun et al., Supercomputing '90